

Packaging Specification of DFN5060 [I1 Type Packaging]



Design Viitor into your FUTURE



1. The method of packaging and dimension are shown as below figure.

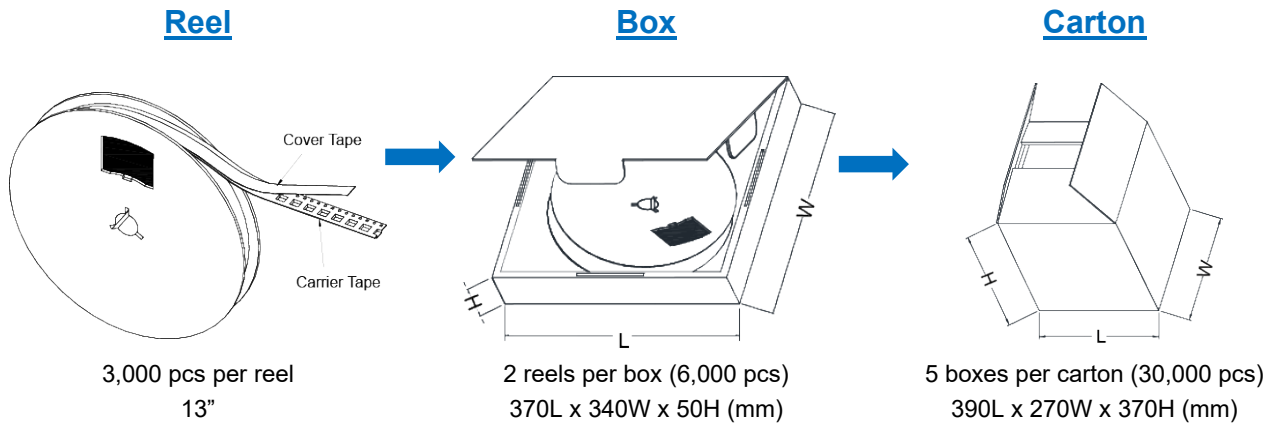

EMBOSSED TAPE AND REEL ORDERING INFORMATION

Package	Tape Width (mm)	Pitch		Reel Size		Per Reel Packing Quantity
		mm	inch	mm	inch	
DFN5060	12	4	0.1575	330	12.99	3,000

2. Label

2.1 The information of inner box label must be listed: (Description of a sample label)



MSL:
RoHS Compliant
P/C:

LOT:	Wafer Number
Part No:	Viitor Part Number
QTY:	Quantity
Date Code:	The first two digits indicate the year while the 3rd and 4th digits indicate the week of manufacture
Customer P/N:	Customer Part Number
P/O#:	Customer Purchase Order Number

2.2 The information of carton label must be listed:

2.2.1 TYPE

2.2.2 QTY